

MA6Gen3 – thin film masks

Version of 2024-11-25.

1. Introduction

This manual shows how to use on the MA6Gen3 thin film masks and transparency sheet masks

They are low cost products, typically printed on a laser printer directly onto transparency films.

At EPFL, [ACI Atelier pour le routage et la fabrication de circuits imprimés](#) prints them for you on a [high precision raster photoplotter "First EIE"](#) films according to these specifications:

- spotsize: 8.5um (red LED at 667nm)
- minimum line width 25um
- maximum linewidth variation: 4um
- formats: RS274D, RS274X, EIE RPL, DPF
- resolution 3000, 6000, 12000 dpi
- maximum area: 500x650mm

2. Situation to avoid / forbidden.

In a straightforward way, a typical transparency mask is scotch-taped to the bottom side of a 5"x5", stripped photomask.

Upon WEC and exposure, this destroys the rubber lip of the chuck and makes it unusable for future vacuum contact users. Don't do this.

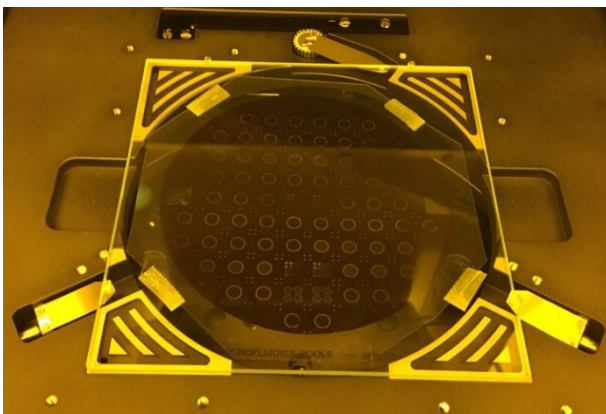

Figure 1: 5"x5" mask with thin film on mask holder.

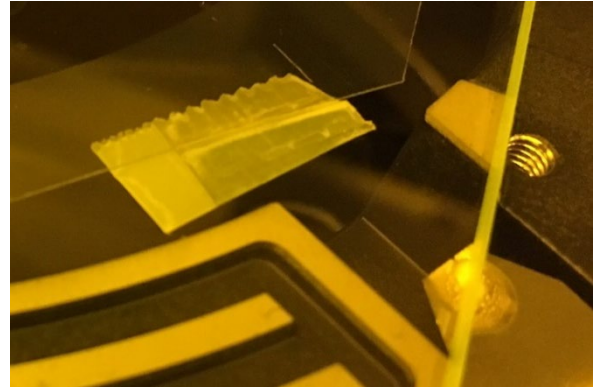

Figure 2: scotch tape tries to be as close as possible to border to avoid touching the wafer on hard contact.

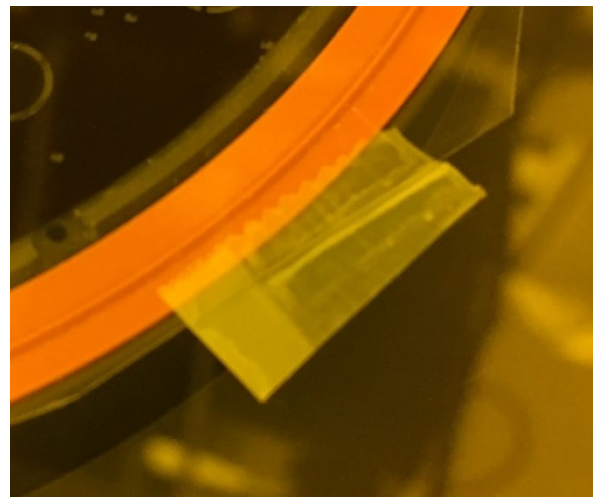

Figure 3: When during WEC, the wafer is pressed against the transparency mask, the scotch tape locally exerts locally high pressure which ages, and ultimately destroys the rubber lip of the vacuum contact chuck. If no damage is done, then traces of the adhesive are deposited on the rubber lip. To avoid these problems, do not use adhesive tape.

3. Mask holder to use with thin films

In general, the size of the transparency masks corresponds to the sheets that are fed to a laser printer, which is A4. Cut your mask to a size equal or smaller than 7"x7", which is the specification of the transparency mask holder of the MA6Gen3, but bigger than the rubber lip of the chuck you intend to use. Read entire manual before cutting.

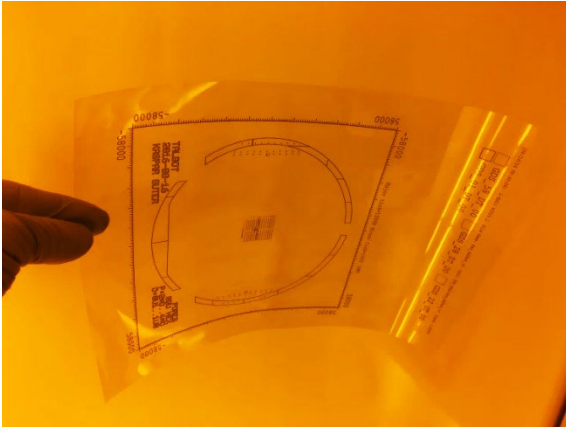

Figure 4: random mask, printed on a A4 size thin film

Attach the thin film to the glass plate. Make sure that the adhesives are away from the area where the chuck will be touching and pressing the substrate against the thin film.

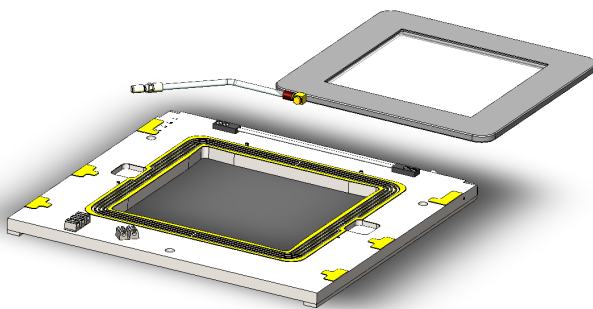

Figure 5: glass plate top view (right), bottom view (left).

Here the manufacturer's information, and there are two parts to it: holder and glass plate.

100073420 MASK HOLDER
 MA8BA8GEN3/TL/CONT/M-9/F-7/S-6/SPEC

- Top load maskholder
- for mask 9"x9" and includes adapter glass 9" for thin film Mask 7"x7"
- for chuck for pieces, wafer 100mm and 150mm
- for contact levelling



9"x9" insert for 7"x7" film mask (connection on permanent vacuum at front panel of front panel)

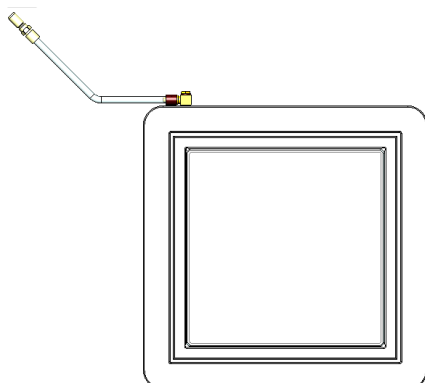

Put the adhesive in places where it cannot touch the chuck, typically in the corners. The film must not overlap the vacuum channel running around the glass plate, otherwise the holder cannot hold the plate.



Figure 6: film attached with adhesives to glass plate

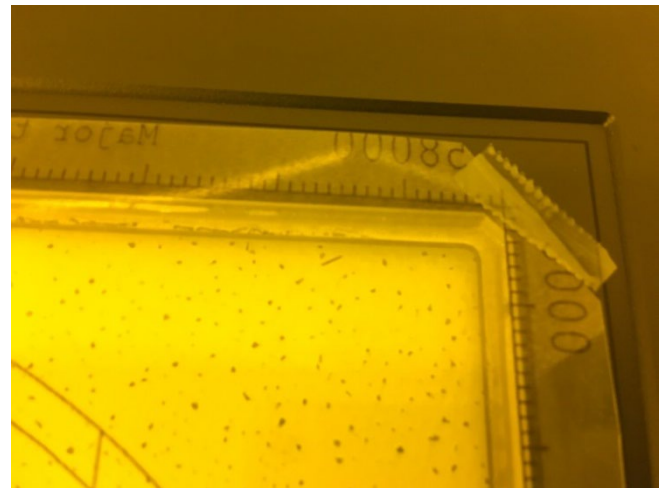

Figure 7: detail of adhesive

